

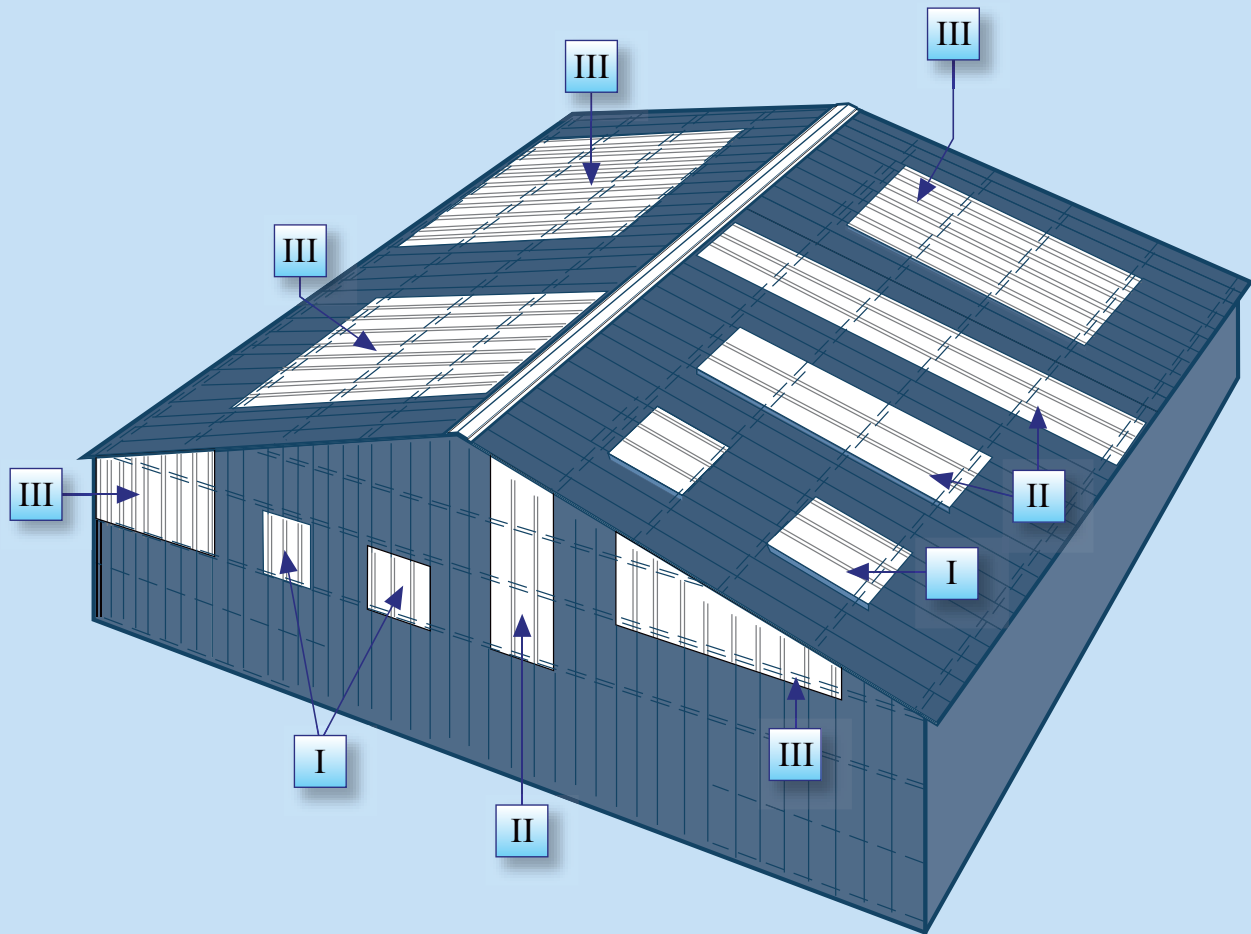

Introduction:

Pro-Sky is a high quality light-transmitting, corrugated polycarbonate panel designed to match Pro-Rib and Premium Pro-Rib panels. It is designed for single or multi-panel skylights or side lights in roofs and walls of metal-clad structures.

Figure 1: Various Pro-Sky Skylight and Side Light Arrangements



- LEGEND**
- I** Single panel, single span
 - II** Single panel run
 - III** Multi-panel run

Transportation, Handling & Storage:

1. Transport and store Pro-Sky panels horizontally on flat, sturdy pallets, equal to or longer than the longest panels. Short panels should be stacked on top of longer ones. The panels should be secured and fastened to the pallet during transportation.
2. Store Pro-Sky panels in a cool and shaded place, out of direct sunlight. Avoid covering the stack of panels with dark or heat-absorbing materials or objects, to prevent solar heat buildup.
3. When necessary to store panels outdoors, cover the stack with a white opaque polyethylene sheet, or another material that does not absorb or conduct heat. Be sure that the entire stack is covered.
4. Pro-Sky panels are tough, requiring no special care. However, we recommend some cautionary steps:
 - Avoid stepping on the panel, driving over the panel, or folding the panel when handling and installing.
 - Avoid dragging the panel on the ground, scraping it against the structural elements, or any other sharp or rough objects, to prevent the panel from getting scratched.



Figure 2

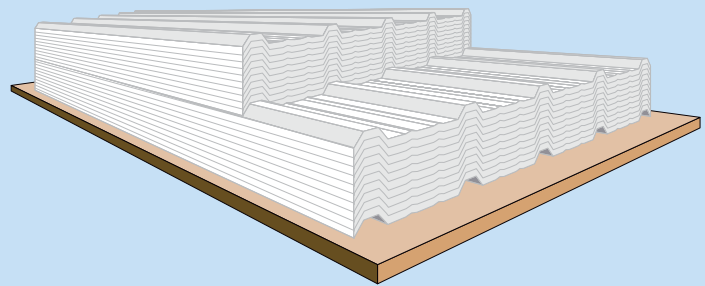

Figure 3

Storage of Panels

Sawing, Cutting & Drilling:

1. Pro-Sky panels can be cut or sawed by manual or power tools. A bench/table circular saw is best for straight long cuts. For better results, cut a few panels together. Portable circular saws are suitable for on-site straight cuts. A jigsaw is used for cutting a limited length of irregular or curved lines. Hand tools such as handsaw, metal shears or hand-held cutting knives can be used for localized, limited work.
2. **Sawing** is done with plywood saw blade, installed in reverse direction, with small teeth, and spinning at high speeds, with a slow feed rate. Panels should be clamped during sawing, to avoid vibrations. Avoid intersecting cuts. Drill a hole at intersection point, then cut the panel up to the hole.
3. **Drilling** is done using a power drill, with regular high-speed steel bits intended for metal, rotating at about 1,000 RPM. Better results with Pro-Sky are achieved using bits ground to shallower tip angle than for metal. Clamp the drilled panel down to avoid vibrations or movement during operation.
4. Keep the cut area clean. Blow away saw and drill dust with compressed air.



Sawing the panels
Figure 4

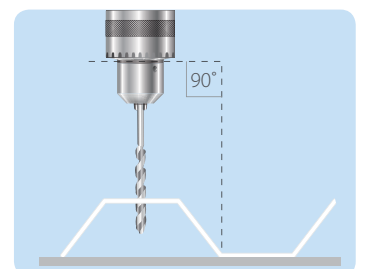

Drilling the panels
Figure 5

Safety Measures (during installation and afterwards):

1. Use ladders, crawling boards and other safety equipment required for safe installation. Be sure to wear appropriate personal protection equipment such as proper gloves, safety glasses, etc. Use all safety measures required according to local safety regulations.
2. Always use appropriate scaffolding to service panels. Scaffolding should provide proper worker safety and ensure proper placement and distribution of weight to avoid damage to panels.
Do not walk on panels for fear of falling and other severe bodily harm.
3. Never leave Pro-Sky panels unattended on the roof until all the required fasteners have been appropriately installed or the panels secured to the supporting structure.
4. Always follow local and/or national building and OSHA safety codes.



WARNING!
Do not step directly on panels between the purlins!
Use scaffolds, ladders, or crawl boards.

Figure 6

Panel Orientation:

1. Pro-Sky's exterior surface is UV resistant,
The protected side is up when panel edges are both pointing down.
2. Installation Direction: For multi-panel runs, begin installation of Pro-Sky on the side away from wind and rain direction.

WARNING!

Fatal falls and serious injuries may result from inadequate guarding and fall protection for work around skylights and roof and floor openings.

General Information for Installation:

1. **Roof Pitch:** Pro-Sky performs best when installed at pitch rates of 10 percent (1":10" slope or 5.7°) or more. If installed at a lower pitch, additional sealing should be applied to ensure weather resistance. A minimum slope of more than 5% is recommended when installing Pro-Sky.
2. **Load Rating and Maximum Recommended Distance** (Typical profile variations are considered the same): The depicted distances refer to a single panel, single-span installation on surrounding supportive compatible metal cladding.
- 2.1 **Load Rating Values:** Pro-Sky panels load rating will vary according to the arrangement of panel(s) and existing or designed spans, as mentioned above.

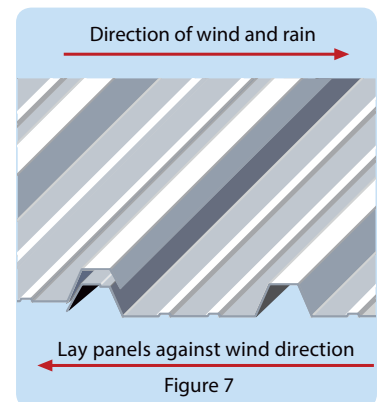

Figure 7

3. **Uplift Testing:** Pro-Sky corrugated polycarbonate panels meet Uplift Test Criteria specified in UL 580 Test for Uplift Resistance of Roof Assemblies (UL Class 90). Consult Palram Americas technical support for additional details if necessary.

Test Description

Roof Covering: Corrugated polycarbonate roof panels with 9 inch spaced corrugations. The tested material comes in 0.032" thick x 38" width and 12 feet long.

Pre-Drill Screw Holes: 5/64" larger than the screw size to allow for expansion and contraction of panel.

Fastener: Use #10 wood screw or #12 self-drilling drilling/ self-tapping screw with a minimum 1/2" neoprene bonded washer.

Uplift Test Results

A buckled hip was visible during the test. The fasteners were in place and no cracks or breaks were found in the Pro-Sky panels. The test assembly withstood all phases of testing for Class 90. The roof assembly described in this report met the uplift test criteria specified in UL 580 - Test for Uplift Resistance of Roof Assemblies. **Note:** The buckled hip returned to the original shape after testing with no panel damage or permanent deformation.

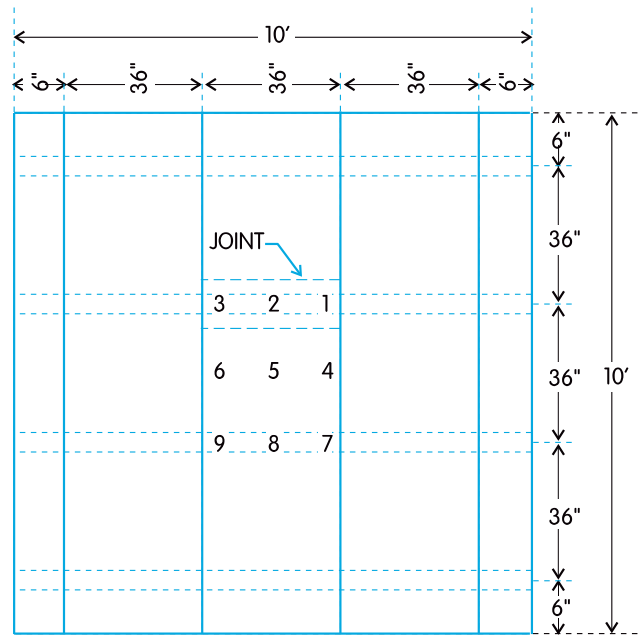

Figure 8

4. **Purlin & Girt Spacing:** Purlin and girt spacing are usually dictated by overall design and engineering calculations along with the whole structure is constructed. Pro-Sky panels are installed at the same purlin/girt spacing as the rest of the metal panels in the structure.

Verify that the installed Pro-Sky panels will remain within the uniform load-supporting limits of deflection as observed by the Evaluation Acceptance tests (see the "Uniform Load" diagrams and "Uplift" paragraphs).

In case purlin/girt spacing of the metal-clad structure surpass the values depicted in the tables by a significant margin (especially in multi-panel runs), a secondary support system, based on data in the above mentioned tables, should be prepared for the Pro-Sky skylight or side light.

When support spacing is marginally larger, on-site environmental conditions should be considered and acted upon.

Installation Comments (Roofing & Siding):

1. **Single Panel Run Installation:** The length (long side) outermost crests of a Pro-Sky panel should lap over matching adjacent crests of metal panels on both sides.
2. **Multi-Panel Run Installation:** The middle Pro-Sky panels should be installed with the regular under/over length overlap (the short crest edge on top of a longer one). The outermost Pro-Sky panels on both length sides will lap over the adjacent matching metal panels, as in a single panel run, unless designed otherwise.

Important! Whenever the extreme side-laps of a skylight or side light side-laps are installed on top of the adjoining metal panels, the overlapping metal panel(s) above the opening should also be installed the same.

3. **Framed Independent Side Light Installation:** An installation method for side lights, requiring framing for the apertures in the siding. Frame details enable installation of any Pro-Sky profile, independent of the surrounding wall cladding.

Aluminum profile framing is very suitable, relatively inexpensive, and available in a wide variety of shapes, and is easy to work with (Custom shapes are available with minimum quantity requirements). Fabricated zinc plated, painted or stainless steel sheet are possible options, moderately priced and easy to fabricate. Wood framing is also possible, especially for small-scale and DIY jobs. Typically, the designs of these structures are more simple to build, and requires only basic everyday tools.

4. **Side-lap Support:** At side-laps where the Pro-Sky edge corrugation has to be installed under the corrugation of the adjoining metal panel, or in Pro-Sky on Pro-Sky side-laps (multi-panel runs) length support profiles, of metal or wood, are recommended. Such length supports ensures better side seal and rigid installation. (See Fig. 17, 32)

Pro-Sky skylights in roofing:

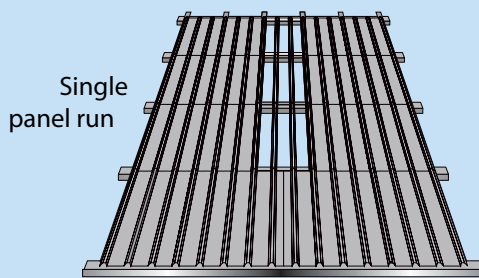

Figure 9

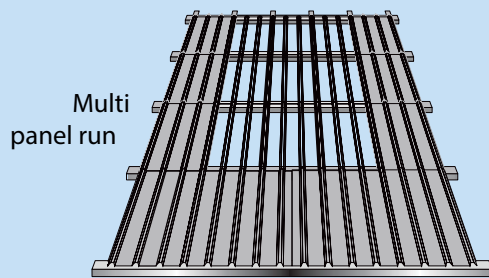

Figure 10

Pro-Sky side lights in siding:

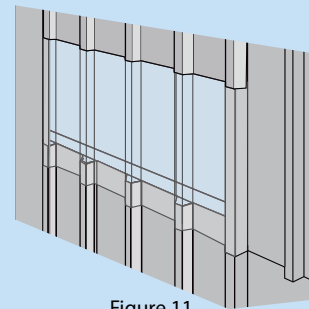

Figure 11

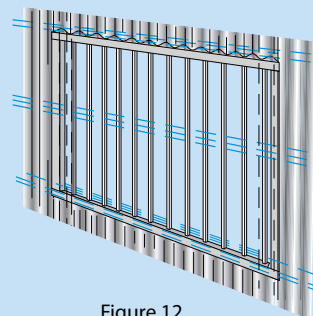
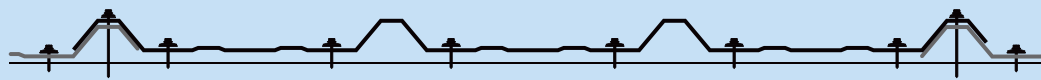

Figure 12

Fastening & Sealing:

Pro-Sky

At edge purlins



At internal purlins

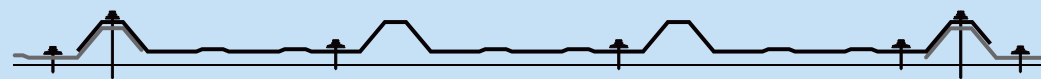

5. Installation & Fastening Tips:

- Allow for expansion & contraction at fasteners:** Pre-drill screw holes $5/64$ " larger than the screw size to allow for expansion and contraction of the panel. Use #10 wood screw or #12 self-drilling/self-tapping screw with a minimum of $1/2$ " neoprene bonded washer. Pro-Sky panels are not installed below 40°F or above 80°F . See Page 17, Table 3, for detailed Pro-Sky Thermal Expansion Data.
- Drive fasteners perpendicular to Pro-Sky face.** Use an adjustable-torque power screwdriver to ensure against over tightening. Avoid distortion of washer/gasket and panel. (See fastener positioning details - Figure 14a and 14b). **Never use an impact wrench/driver for fastening Pro-Sky.**
- Installation Direction:** We recommend starting installation from the bottom up, on one side, and work to the left or right accordingly. **Never start working from both ends to the middle.** Always lap the top panel over the lower one.
- Keep panel straight, flush and taut during installation.**
- Do not over tighten**
- Side-Lap Support:** At a side-lap of metal on Pro-Sky or two Pro-Sky panels (multi-panel installation) a lengthwise wood or steel support bar may be required.
- Fastening Details** (Schematic Figures 15, 16, 17, and 18):
 - Pro-Sky panel
 - Adjoining metal panel
 - Valley fastener
 - Metal crest / valley fastener
 - Side-lap fastener
 - Side-lap stitching fastener
 - Butyl-rubber or expanding sealing strip

h. Fasteners Positioning Comments:

- Generally, valley fasteners should be installed at the top & bottom edges, and at end-laps of Pro-Sky panels, as shown on Page 8, Section J, Figure 13.
- In multi-panel runs, the number of fasteners can be reduced at mid-purlins, unless conditions demand otherwise. The remaining fasteners should be evenly positioned adjoining the main corrugations of the specific panel.
- Stitching screws should be distributed 12"-16" apart. For polycarbonate to polycarbonate side laps, please use the 1" Rubber grommet shown in Table 2 Recommended Fasteners.

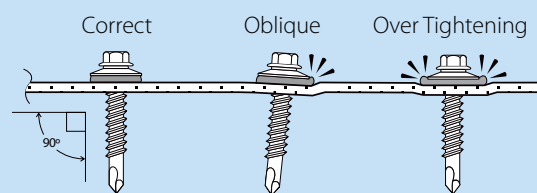

Right & wrong fastener insertion

Figure 14a

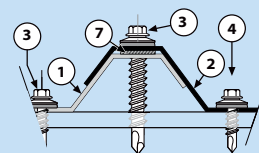

Figure 15

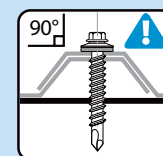

Figure 14b

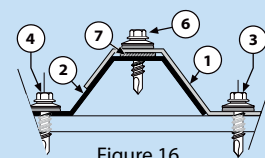

Figure 16

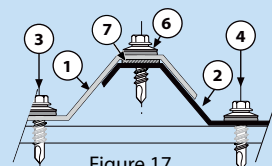
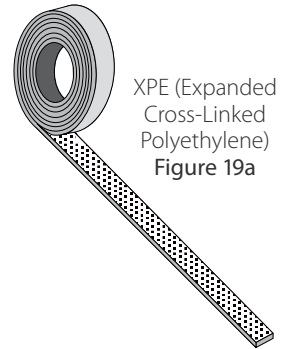

Figure 17

6. Sealing Pro-Sky:

- a. **Self-Adhesive XPE Sealing Tape** (Expanded Cross-Linked Polyethylene): Resilient, closed cells, self-adhesive foamed-polyethylene to be applied at sides & end-laps, on top of the overlapped area. Cross-section dimensions may vary according to specific requirements. A typical XPE tape is 3/4" (20.0 mm) in width, 3/16" (5.0 mm) in thickness and comes with pressure sensitive adhesive on one side, protected by silicone paper.



Butyl-Rubber or Expanding Sealing Tape: Elastomeric or Expanding Sealing Tape to be applied at side & end-laps, on top of the overlapped area. Do not use mastic tape.

Install as follows: (See Page 9, Figures 15-18 and Page 11, Figures 20-22) Remove bottom protective paper strip progressively, as installation advances. Apply carefully by hand.

- **Single seal end-lap:** Apply along fasteners' center-line at the end-lap, following the profile shape.
 - **Double seal end-lap:** Apply above and below fasteners' center-line at end-lap, following the profile shape.
 - **Single seal side-lap of Pro-Sky over metal panel:** Apply on top of center-line of side corrugations.
 - **Single seal side-lap of metal over Pro-Sky panel:** Apply between to the down facing corrugation of the metal panel and the Pro-Sky panel to prevent capillary action.
 - **With butyl-rubber only:** Remove top protective paper strip before laying the overlapping panel. Lay the edge of lapping panel and apply moderate hand pressure on the top panel along the side corrugation, to ensure a proper seal.
- b. **Top & Bottom Contoured End Closures:** Top or bottom matching closure strips close the opening above or below the panel and its corrugations.

Install as follows: Place the closure strip at the top or bottom edge fasteners' center-line, and insert the fasteners through said strip so it will be held firmly in place. A few dabs of silicone could hold the strip temporarily in place until the top panel is laid and screws are inserted. (Figures 23a, 23b, 24a & 24b)

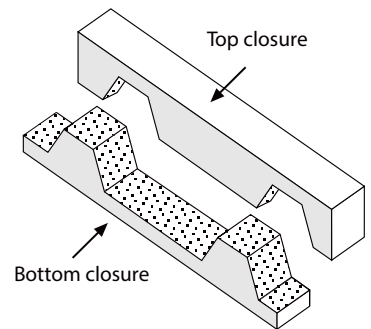

Top & Bottom End Closures
(Pro-Sky 12")
Figure 19b

- **Location A:** Where Pro-Sky runs reach the top or bottom of roof or wall edges, or at the roof ridge, the space left between the panel's profile and the purlin, or girt, should be closed and sealed with a contoured foam, polyethylene (XPE) closure strip matching the panel profile.
 - **Location B:** Where Pro-Sky runs reach a top trim, or at a ridge-cap, a top closure strip should be used at the top edge above the panel.
- c. **Silicone Sealants:** *Sealants, adhesives or bonding materials may be found to be incompatible, and can chemically attack the panels, originate failure, and revoke any and all warranties. Please contact sealant manufacturer to insure it's compatibility with polycarbonate prior to use. Palram Americas, Inc. will not be responsible for panel failure due to chemical incompatibility with the sealant.*

Side & End Lap Installation:

End lap (or width overlap - short side) of a Pro-Sky panel on another consecutive Pro-Sky or metalpanel, should always be done over a supporting purlin. Each of the panels involved should overhang the purlin center-line by about 3" (2" minimum and 4" maximum), totaling an average overlap of 6".

Fastener and Sealing Tape Locations

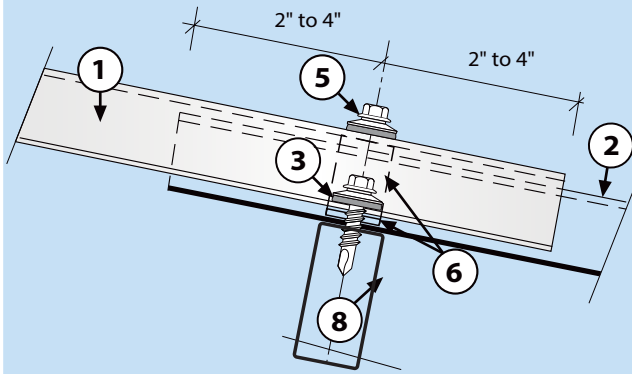

End-Lap Detail
Figure 20

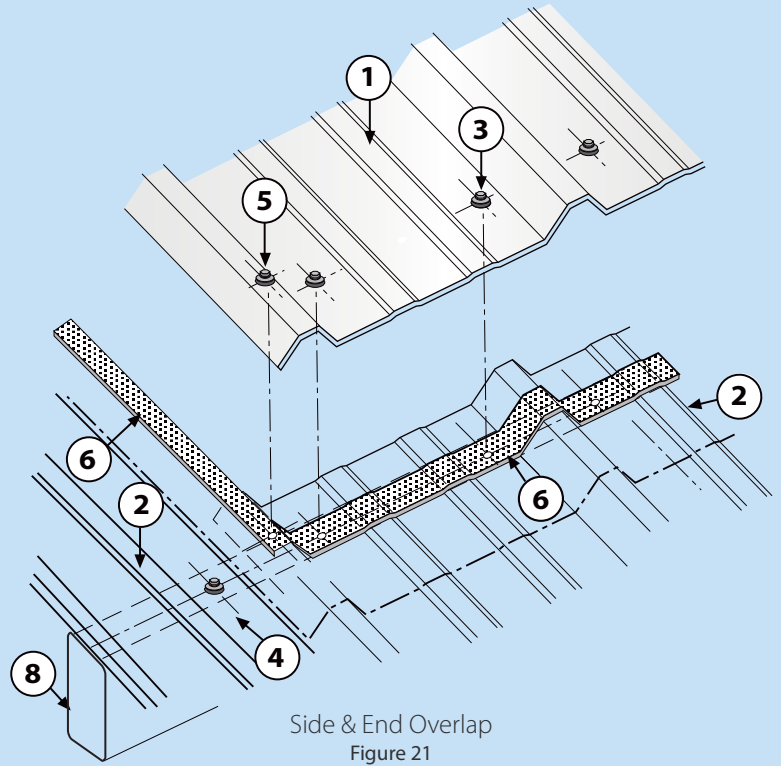

Side & End Overlap
Figure 21

Legend

- ① Representative Pro-Sky panel
- ② Representative panel
- ③ Pro-Sky valley fastener
- ④ Typical sheet-metal crest or valley fastener
- ⑤ Pro-Sky crest (side-lap) fastener
- ⑥ Sealing tape installed along side & end lap corrugations
- ⑦ Shaped bottom-end closure
- ⑧ Supporting purlin
- ⑨ Optional drainage gutter

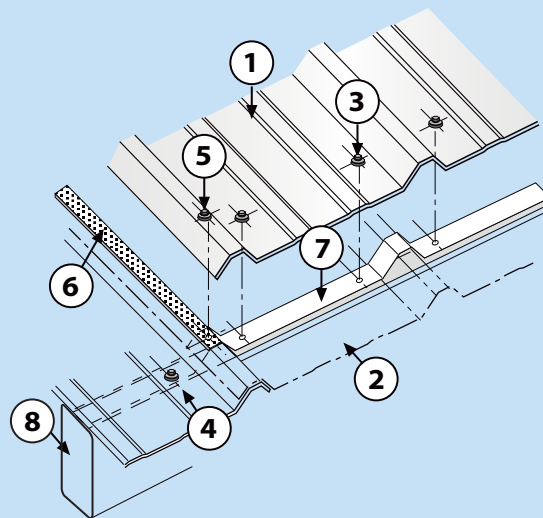

Bottom Edge Pro-Sky Installation
with Profiled Closure Strip
Figure 22

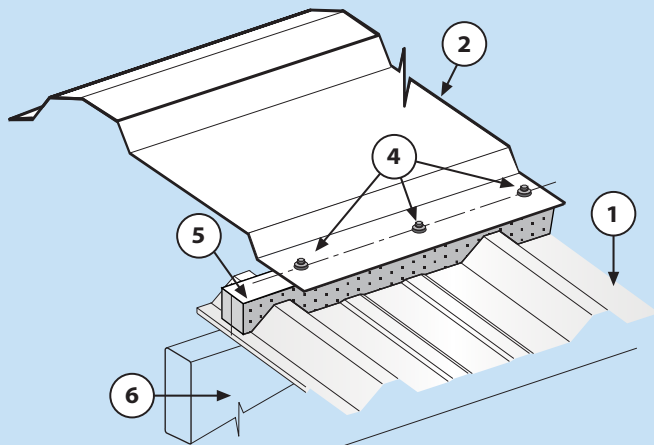

Pro-Sky Ridge Cap Fastening
Figure 23a

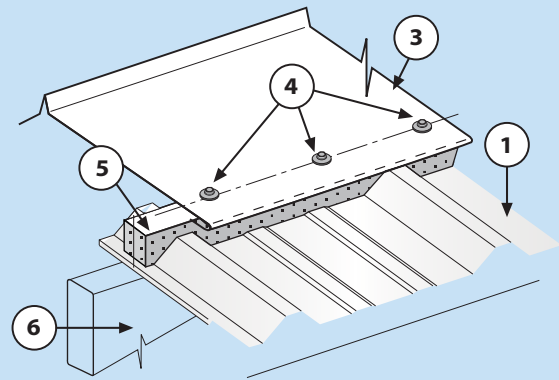

Sheet-Metal
Ridge Cap Fastening
Figure 24a

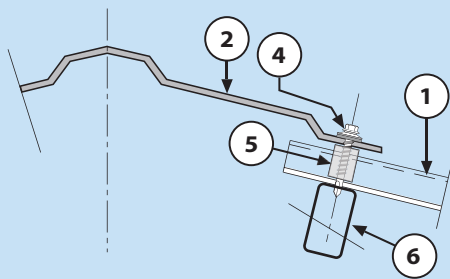

Pro-Sky Ridge Cap Fastening
& Top Partial Section
Figure 23b

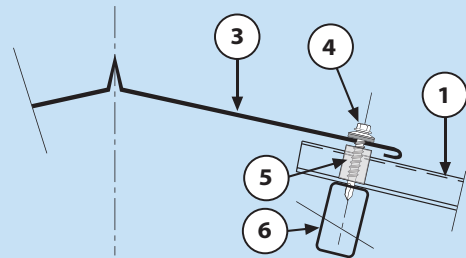

Sheet-Metal Ridge Cap Fastening
& Top Partial Section
Figure 24b

Legend

- ① Representative Pro-Sky panel
- ② Pro-Sky Universal Ridge Cap
- ③ Sheet-metal universal ridge cap (typical)
- ④ Crest fastener (side-lap)
- ⑤ Shaped Foam Closure (fits topside of panel)
- ⑥ Supporting purlin

Important notes about installation of Pro-Sky Ridge Caps

1. Do not over tighten screws when installing. If ridge cap deforms, screws are too tight.
2. Use recommended fasteners as shown on page 8, Table 2.
3. When installing clear ridge caps on wood purlins, purlins should be painted with white acrylic-based paint prior to installation. This will help prevent overheating and possible charring of the purlins.

Options for Installation:

1. **Single width, single span installation** (on 2 edge support purlins), integrated and surrounded by matching metal panels, overlapped on top, overlapping and supported on both sides and at the bottom. This dictates that the top metal panel is also installed with its edge corrugations overlapping at both sides, up to the roof edge or ridge.

Legend

Connections

- A** Right side-lap: metal panel overlaps Pro-Sky panel
- B** Left side-lap: Pro-Sky panel overlaps metal panel
- C** Top end-lap: top metal panel laps over top edge of Pro-Sky panel
- D** Bottom end-lap: bottom edge of Pro-Sky panel laps over top edge of metal panel
- E** Bottom edge detail: Pro-Sky panel at the bottom edge of a roof, with or without a gutter

Components

- ① Representative Pro-Sky panel
- ② Metal panel
- ③ Pro-Sky valley fastener
- ④ Typical sheet-metal crest or valley fastener
- ⑤ Pro-Sky crest (side-lap) fastener
- ⑥ Pro-Sky side-lap stitching fastener
- ⑦ Foam closure (underside shape)
- ⑧ Supporting purlin
- ⑨ Main supporting truss / beam
- ⑩ Optional drainage gutter

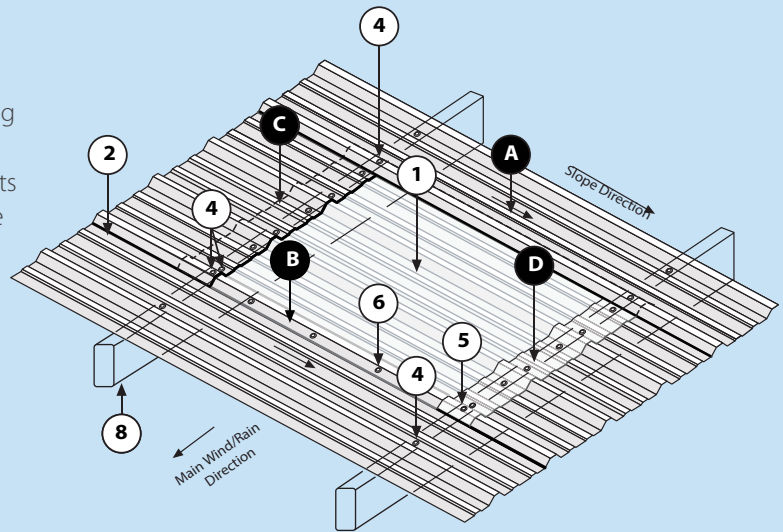

Typical, Single Panel, Single Span Mid-Field Detail
Figure 25

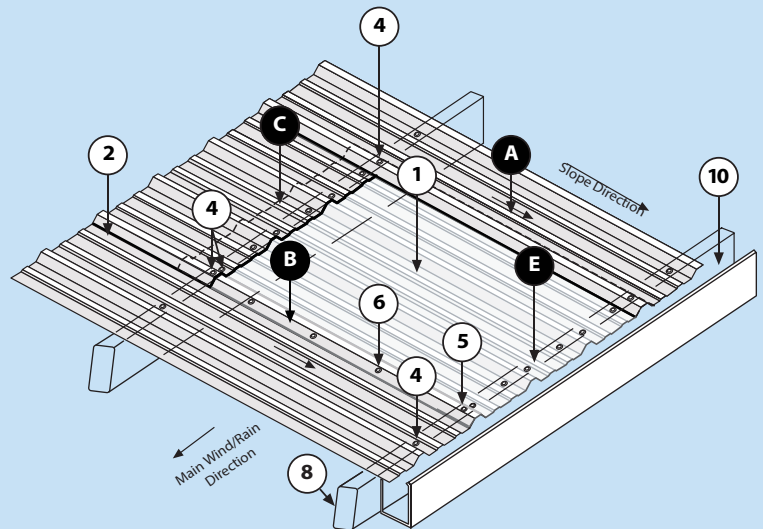

Typical Bottom End
Pro-Sky Detail (with or without gutter)
Figure 26

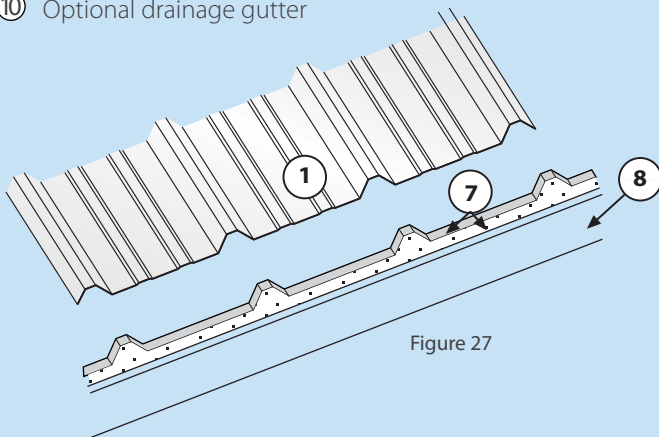

Figure 27

2. **Single width, multi-span installation**, on a few support purlins, using one single long panel or a few consecutive ones, overlapping each other (See Single-Panel Runs, page 7, fig. 9).

This option can be implemented by two possible alternatives:

- Installed mid-field, surrounded by matching metal panels, overlapped on top, overlapping both sides & bottom.
- Installed from top to bottom or from ridge to bottom (one or two way pitched roof). This alternative enables the use of Pro-Sky panels on metal roofs with profiles that don't exactly match.

Both alternatives allow Pro-Sky panels installation on top of outermost length corrugations of metal panels on both sides, for tougher, stiffer installation with better sealing, enabling easy installation of the Pro-Sky skylight panels after the metal roofing is already in place (proper clearance must be provided for).

3. **A multi-width, multi-span installation** (See Multi-Panel Runs, page 7, fig. 10).

This can be implemented the same way as the two alternatives mentioned above, either as an integrated part of a roof plane, or as an independent roof, its edges overlapping the metal panels on its two sides.

4. When installing Pro-Sky on glass fiber mats insulated steel roof, be sure to use a suitable spacer along the purlins and avoid any contact between the vinyl finish of the mats and the Pro-Sky panels (fig. 29, 30).

Legend

- ① Representative Pro-Sky single / single-run multi-run skylight panel, overlapping lengthwise on both sides
- ② Typical metal panel installed on all sides
- ③ Pro-Sky valley fastener
- ④ Typical sheet-metal crest or valley fastener
- ⑤ Pro-Sky crest (side-lap) fastener
- ⑥ Pro-Sky side-lap stitching fastener
- ⑦ Butyl-rubber sealing strip installed along width & length end corrugations at all overlap.
- ⑧ Height equalizing shim - wood or rigid plastic bar of suitable thickness compensating for the thickness of the insulation mat at the purlins
- ⑨ Supporting steel purlin
- ⑩ Main supporting structure
- ⑪ Galvanized sheet-metal strip for insulation mat support
- ⑫ Glassfiber or rockwool insulation mat underneath the steel roofing with reinforced aluminum foil or vinyl film bottom finish, supported by the metal strips
- ⑬ End of insulation mat at the lower edge of the skylight with the mat edge tucked back and under metal to create a nice edge finish

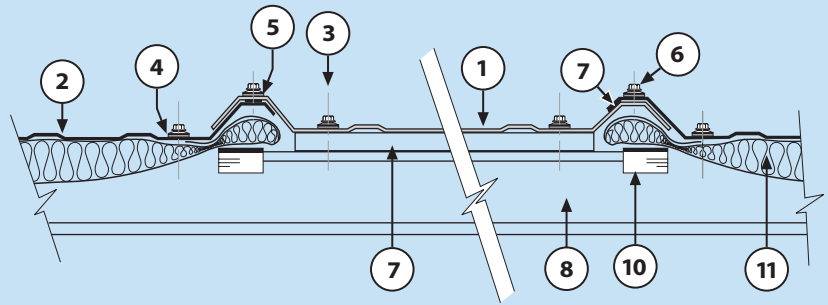

Width Cross-Section Detail
Figure 29

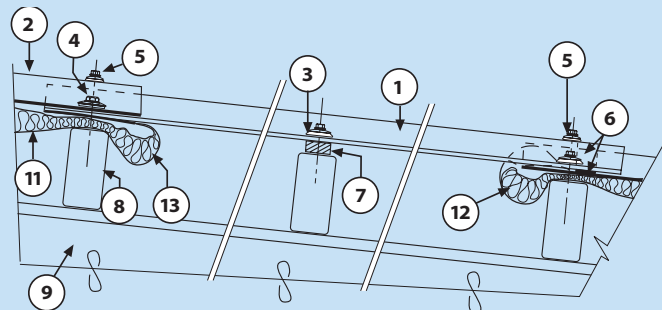

Length Section Detail
Figure 30

⑭ Same as ⑬ but at the upper edge of the skylight, and at vertical edges. **Caution:** The vinyl used on insulation make be incompatible with Pro-Sky. Insert a separative layer between the Pro-Sky sheet and the tucked-back vinyl-covered insulation to prevent potential out-gassing damage to the Pro-Sky panel.

5. Installing Pro-Sky Side Lights on

Exterior Walls: When installing, fastening and sealing side lights, follow the same general procedures for roof installation as described on the preceding pages.

Certain installation methods are specific to siding installation, like the framed Side Light.

Typical Side Light Applications:

- A** Multi-panel, single-span
- B** Single-panel, multi-span
- C** Multi-panel, multi-span
- D** Single-panel, single-span (Figure 11)
- E** Framed Side Light (Independent of surrounding cladding type)

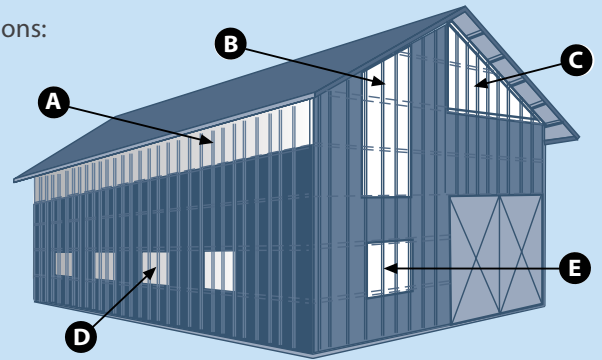

Typical Side Light Applications
Figure 31

Framed Side Light Details

- ① Side Light panel
- ② Surrounding cladding
- ③ Top & bottom valley fasteners
- ④ Mid-field fasteners
- ⑤ Side light framing (a.k.a. Z or H channel)
- ⑥ Wood/steel main frame

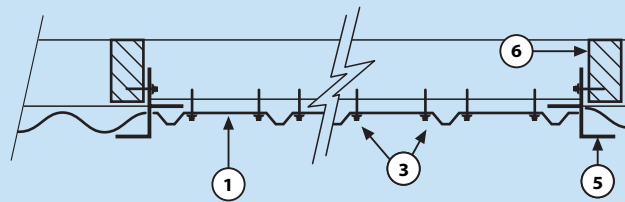

Framed Side Light
Horizontal Section
Figure 32

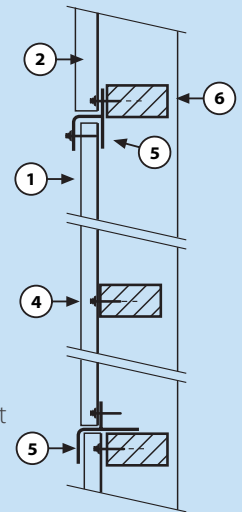

Typical Side Light
Vertical Section
Figure 33

Integrated Side Light Details

- ① Pro-Sky side light panel
- ② Metal panel
- ③ Pro-Sky valley fastener
- ④ Sheet-metal fastener
- ⑤ Pro-Sky crest fastener
- ⑥ Side lite metal or wood length support
- ⑦ Wall girt
- ⑧ Roof-edge Z purlin
- ⑨ Eave-strut
- ⑩ Main supporting frame
- ⑪ Structural corner profile
- ⑫ Sheet-metal corner trim
- ⑬ Shaped foam closure (underside shape)

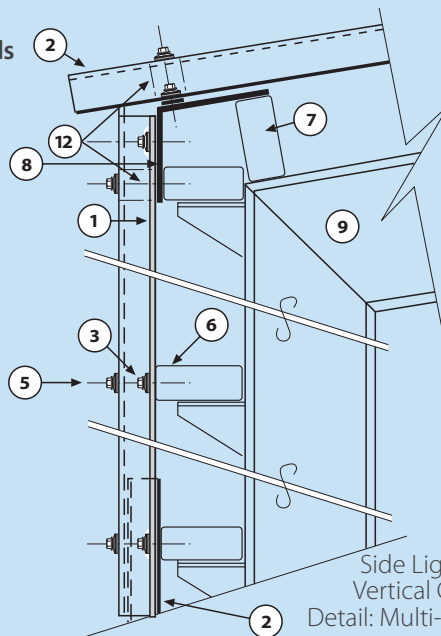

Side Light Fastening
Vertical Cross-Section
Detail: Multi-Panel Run Option
Figure 34

Important Installation Comments:

1. **Avoid over-tightening the fasteners.** Allow gaskets to squeeze slightly until full contact with panel. Over tightening induces undue internal stresses, leading to premature failure. **Regular Washer / Gaskets (Tek Screws) for metal panels apply excessive pressure, are inadequate for Pro-Sky sealing, and cause undue internal stresses in the panel. The stresses result in crazing, fractures, and eventual failure.**
2. **Never use** soft PVC (vinyl) washer / gaskets. Soft PVC is totally incompatible to polycarbonate and will harm the panel.
3. **Never apply** paints, shading compounds, paint thinners or any material that may chemically attack Pro-Sky, without first verifying compatibility to the panel.
4. **Always work safely.** Follow safety recommendations in the Installation Instructions.
5. **Maximum span:** Net spans should not exceed 5' to avoid buckling due to thermal expansion. Reference profile specific technical addendums on page 2.
6. **Fastening:** Always use recommended fasteners (Table 2, Page 8) for securing Pro-Sky. Never install Pro-Sky by nailing.
7. **Isolating Pro-Sky from harm:**When placing Pro-Sky on asphalt shingles, soft PVC or vinyl, or other incompatible materials, use an isolating barrier, metal or wooden strips, EPDM rubber patch etc., between the panel and a material of questionable compatibility.
8. **Extra Fastening:** On length runs, where Pro-Sky overlaps metal panels on both sides, we recommend side stitching fasteners beside the main fasteners connecting the Pro-Sky to the frame. These should be spaced along the side-laps about 12-16" apart.
9. **End-Lap Support:** Pro-Sky / metal or Pro-Sky / Pro-Sky panel end-lap should always be fully supported, to avoid deflection at that area. This also applies to ridge-cap/Pro-Sky end-lap.
10. **Support Profiles:** At Pro-Sky / Pro-Sky or metal / Pro-Sky side-lap (length overlap), metal or wood length support bars can be added under the side-lap to minimize deflection, assisting in sealing & stitching. The length support bars should be sized to suit the corrugations.
11. **Silicone Sealant:** 100% silicone sealant (see page 10, section 6c). **Unapproved sealing or bonding material may be incompatible, damage the panels, cause failure and void warranty.**
12. **Butyl-Rubber Seals:** Side-laps and End-laps of any Pro-Sky profile should be treated with butyl-rubber or expanding tape, placed between the overlapping panels at all edges. In shallow pitch roofs (less than 5 percent) double (parallel) sealing strips are recommended at end-laps.
13. **Shaped Foam Closures:** Expanded foam polyethylene (XPE) closure strips are used to seal the space between the upper or lower Pro-Sky profile to edge purlins or ridge caps. Matching XPE top & bottom strips are available for each major Pro-Sky profile. The strip is held in place by the screws fixing the panel to the purlin. (see figures 23a, 23b, 24a, and 24b, on page 12 and figure 28 on page 13).
14. **When installing clear Pro-Sky,** it is advisable to paint purlins using white acrylic paint, or to cover with aluminum tape, in order to prevent over-heating and / or charring of the purlins.

14. **Cleaning:** Most normal dirt & dust accumulation is washed off by periodic rains. Regular hosing of the panels with clean lukewarm water is sufficient in dry areas.

In polluted, oily environments, mild household detergent may be used, assisted by a soft rag or soft-bristled brush. **Never use aggressive or abrasive cleaning agents or glass window cleaners.** They may scratch or chemically attack the panel. Large areas can be washed by high-pressure water-jet, optionally, in conjunction with diluted detergent. Dry with soft cotton rags to avoid spotting.

15. **Repair:** Minor damages to the panel may be repaired. Small punctures can be stopped by dabs of approved silicone sealant. Larger tears may be patched by pieces of matching panel, bonded & sealed on top of the tear with compatible structural silicone.

16. **Study and Preparation:** Prior to actual installation study the Pro-Sky Installation Guide carefully. Make sure all the instructions are understood and all required materials, accessories and tools are available.

Thermal Expansion Table for Pro-Sky Corrugated Polycarbonate

Palram recommends that Pro-Sky panels are not installed below 40°F or above 80°F. See Page 9, Section 5a, for important notes about pre-drilling panels with oversize holes to accommodate expansion and contraction of panels.

Table 3 Thermal Expansion Data

Panel Length		ΔL (Inches) where $\Delta T =$				
Ft	Inches	20°F	40°F	60°F	80°F	100°F
8	96	0.071	0.142	0.213	0.284	0.355
10	120	0.089	0.178	0.266	0.355	0.444
12	144	0.107	0.213	0.320	0.426	0.533
16	192	0.142	0.284	0.426	0.568	0.710
24	288	0.213	0.426	0.639	0.852	1.066